

Original Article

Evaluation of Five In-Line Hematocrit Monitors

Scott Niles, BA, Robert Cronbaugh, BS, James Engle, BS, James Ploessl, CCP, Robin Sutton, MS, CCP

University of Iowa Hospitals and Clinics, Perfusion Technology Program,
Department of Surgery, Division of Cardiothoracic Surgery
Iowa City, Iowa

Presented at the 32nd Annual International Conference of the American Society of Extra-Corporeal Technology, Anaheim, California, April 8-11, 1994. Recipient of the Scientific Presentation Award as the outstanding presentation by a student or first-time presenter.

Keywords: extracorporeal circulation; cardiopulmonary bypass monitor; accuracy; in vitro; hematocrit

ABSTRACT

Monitoring the hematocrit is essential during cardiopulmonary bypass for efficacious administration of blood products. The purpose of this study was to evaluate five cardiopulmonary bypass in-line monitors designed to display continuous hematocrit or hemoglobin values. The devices were evaluated for accuracy using an in vitro circuit primed with human blood while randomizing hematocrit, blood flow rate, and temperature. Hematocrits correlated significantly with the error in all the devices ($p < 0.01$). Over evaluation time, the error of the CDI, Gish, IBC, and MX2 increased significantly ($p < 0.05$). Temperature correlated significantly with the error of the Gish device ($r = -0.49$, $p < 0.01$). Blood flow correlated significantly with the Gish error ($r = -0.24$, $p < 0.01$). The Cobe device had a significantly smaller overall error than the other devices ($p < 0.001$). Device evaluation, based on a low mean error, a low percent error, a high correlation with the actual hematocrit, low correlations between mean error, blood flow, and temperature, and insignificant correlation between time and error, suggests that the Cobe device is more accurate for the continuous monitoring of hematocrit during cardiopulmonary bypass.

Address correspondence to: Scott Niles, University of Iowa Hospitals and Clinics, Perfusion Technology Program, Department of Surgery, Division of Cardiothoracic Surgery, 1600 JCP, Iowa City, IA 52242

INTRODUCTION

Since the genesis of cardiac surgery some forty years ago, cardiopulmonary perfusion techniques, devices, and instrumentation have made remarkable advances in providing optimum patient safety standards. However, specific physiological changes, of varying degrees, are known to occur during cardiopulmonary bypass (CPB) support (1-3). Cardiopulmonary bypass disturbs the normal characteristics of blood flow and gas exchange, and has been demonstrated to alter or activate cellular, humoral, and immune components of blood (1,3).

Utilizing nonhemic priming solutions for CPB circuits has been demonstrated to be a useful adjunct in the management of CPB cases, by improving circulation within the microvasculature, reducing perfusate viscosity, increasing glomerular filtration, and reducing shear forces on blood erythrocytes (3,4,5). In addition, hemodilution significantly reduces patient exposure to risks associated with homologous blood transfusion, such as infection, antibody formation, hypersensitivity reactions, and potential citrate toxicity (1,6,7).

The safety of asanguineous priming solutions in cardiac surgery, resulting in hematocrits ranging from twenty to twenty-five percent, has been well established. However, hematocrits must be carefully monitored to ensure adequate oxygen carrying capabilities and blood buffering (1,8).

A monitoring device that could accurately predict hematocrit levels would be extremely useful in determining oxygen extraction rates. This type of device would also allow efficacious administration of blood products during CPB. Continuous in-line monitoring has been shown to assist in the safe management of CPB procedures by providing the perfusionist with additional information regarding patient status in real time fashion (9).

The purpose of this research is to determine the ability of currently available, in-line, hematocrit/saturation monitors, to accurately predict hematocrits in vitro over a wide range of temperatures, hematocrits and flows. The devices evaluated were the 3M Health Care CDI 100^a, the Medtronic MX2^b, the Gish Statsat^c, International Biophysics Corporation HaemO₂Sat^d, and the Cobe Cardiovascular HCT/SAT^e monitors.

MATERIALS AND METHODS

An in vitro circuit was assembled utilizing five extracorporeal in-line hematocrit monitors placed in series (Figure 1). The circuit consisted of 3/8" and 1/2" polyvinyl chloride tubing^f, a membrane oxygenator^g, an open venous reservoir with integral saturation/hematocrit connector^h, an adult hemoconcentratorⁱ, and a roller pump^j.

- a 3M Health Care, Tusin, CA 92680
- b Medtronic Cardiopulmonary, Anaheim, CA 92807
- c Gish Cardiopulmonary, Santa Ana, CA 92705
- d International Biophysics Corporation, Austin, TX 78753
- e Cobe Cardiovascular Inc., Arvada, CO 80004
- f Baxter Bentley, Irvine, CA 92714

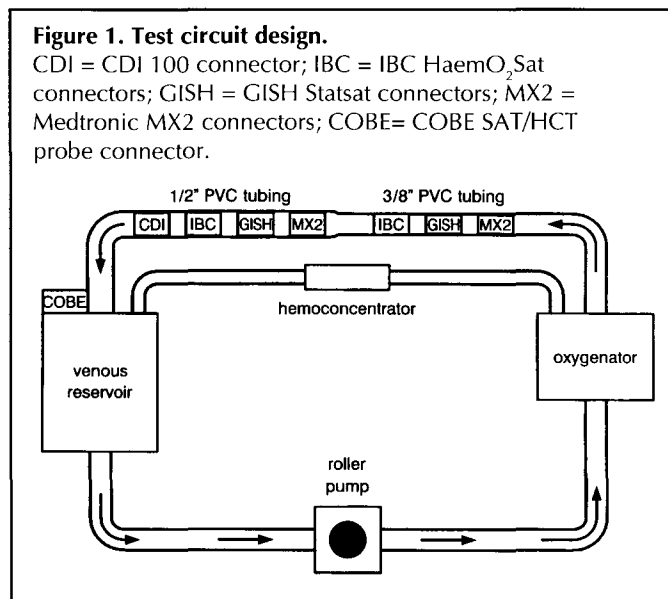

Three of the monitors, the Gish Statsat, the IBC HaemO₂Sat and the Medtronics MX2 Oxygen Saturation and Hematocrit System, employed both a 3/8" line connector and a 1/2" line connector. The CDI 100 monitor utilized a single 1/2" line connector. The Cobe SAT/HCT monitor requires a single fiber optical probe be inserted into the fitting on the Cobe venous reservoir. A minimum distance of six inches was maintained between each connector. Connectors in the 1/2" and 3/8" line were inserted in identical sequence.

Each monitor was allowed sufficient time to warm up while the circuit was primed. The prime consisted of outdated human bank blood (packed erythrocytes), and fresh frozen plasma. Hematocrit levels were adjusted by the addition of lactated Ringersⁱ or hemoconcentration, and verified by a spun hematocrit utilizing a centrifuge^k. Upon attaining a predetermined level of hematocrit, temperature, and blood flow, within recommended operating ranges of all devices, each instrument was calibrated according to the manufacturer's recommendation. The IBC device displays hemoglobin rather than hematocrit and was therefore adjusted to one third the hematocrit value. Device output was not altered or updated once initial calibration was achieved. Test parameters of hematocrit, temperature, and blood flow were randomized utilizing a personal computer with a random number generator. As the randomized levels of hematocrit, temperature, and blood flow were attained, instruments were allowed five minutes to stabilize before displayed values were recorded. Hematocrits were set at 10, 15, 20, 25, and 30%, temperatures at 15, 20, 25, 30 and 37°C, and blood flows at 2, 3, 4, and 5 L/min.

- g Model CM50, Baxter Bentley, Irvine, CA 92714
- h HVR 3700, Cobe Cardiovascular Inc., Arvada, CO 80004
- i Model HP-600, Minntech Corporation, Minneapolis, MN 55447
- j Baxter Healthcare Corp., Chicago, IL 60015
- k International Equipment Company, Needham Heights, MA 02194

Table 1: Mean errors and correlation with actual hematocrit.

Device	Hematocrits 10 to 30%		Hematocrits 15 to 30%	
	Mean error (%) ± SEM	Correlation	Mean error (%) ± SEM	Correlation
CDI	4.0 ± 0.5	0.72	1.6 ± 0.2	0.97
COBE	-0.5 ± 0.1	0.99	-1.0 ± 0.1	0.99
GISH	-4.7 ± 0.3	0.95	-3.9 ± 0.3	0.90
IBC	13.1 ± 0.5	0.30	9.0 ± 0.7	0.83
MX2	5.1 ± 1.0	-0.21	0.4 ± 0.4	0.86

Mean error = Σ (Actual hematocrit - Device reading)

SEM = Standard error of the mean

Combinations of these variables totaled 100 data points.

The data was analyzed using correlation between actual and device hematocrits, between device error and hematocrit, blood flow, temperature, and time. One-way analysis of variance was utilized to compare the mean errors of the devices. The Bonferroni method was utilized for multiple-comparison analysis. Mean device error was compared to zero utilizing a Student's t-test. Significance was said to exist for $p < 0.05$.

RESULTS

Mean error (percent ± standard error of the mean) and correlation with actual hematocrit between 10% and 30%, and a subset of that range (15% to 30%), are recorded for each device in Table 1. A Student's t-test revealed the mean error of all the devices, in each range, to be significantly different from 0 ($p < 0.01$). The Cobe device exhibited the lowest mean error (-0.5 ± 0.1 percent) ($p < 0.001$). The error of all devices correlated significantly with the actual hematocrit ($p < 0.05$) Figures 2 through 6 are scatter plots of actual versus device outputs. Overlapping data points ($n = 100$) are represented by squares in each graph. A best fit line of device outputs was constructed (solid line) for each plot, and an ideal slope (dashed line) indicates zero error. The Cobe device demonstrated the highest correlation with actual hematocrit ($r = 0.99$) (Figure 3).

Statistical correlation between time and device error revealed all device error, with the exception of the Cobe, to be significantly correlated with evaluation time ($p < 0.05$). Further statistical analysis demonstrated that only the error of the Gish device was correlated with temperature ($r = -0.49$) and blood flow ($r = -0.24$). Temperature related error increased from 2.5% at 15°C to approximately 7% at 37°C. Increasing pump flow from 2 to 5 L/min increased the error of this device from 3% to 5%.

DISCUSSION

The greatest attribute of continuous in-line monitoring lies

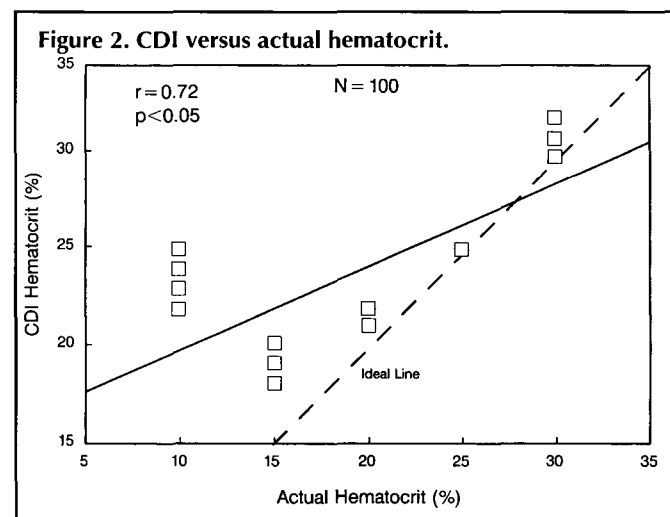

in its characteristic ability to continuously alert the perfusionist to rapidly changing physiologic conditions. At worst, these devices provide unnecessary additional information regarding patient status, and at best they may help form more prudent decisions regarding appropriate patient management. The justification for the utilization of these devices must ultimately confirm definite advantages concerning issues of device reliability and cost-effectiveness.

Perfusionists want to know what parameters influence device error, how often laboratory analysis are needed, and if a certain device can be operated cost-effectively. Unfortunately, the decision to utilize a device or not, is due to the influence of colleagues, marketing campaigns, and product claims. In this product study, we attempted to evaluate five commercially available in-line hematocrit/saturation monitors to answer these questions.

It is often essential to monitor hematocrit during cardiopulmonary bypass, to balance oxygen delivery with tissue demands, and to make appropriate decisions regarding bank blood usage. Although specific criteria regarding administration of homologous red blood cell concentrates will vary amongst, and within institutions, we believe that a device capable of accurately measuring hematocrit within a two percent error would be a valuable asset in patient management.

The recent availability of five devices capable of in-line hematocrit/saturation monitoring, prompted this in vitro evaluation to assess their accuracy in predicting actual hematocrits. Although the specific technology incorporated into the design of each of these devices relies on proprietary functional aspects, the fundamental principles of operation are shared among devices. Each of these devices utilizes a method of transmitting a dual wavelength light pulse via light emitting diodes that, when reflected back to the device sensors, represent the proportion of oxyhemoglobin and deoxyhemoglobin. The results are then interpreted by the device and expressed as oxygen saturation and hematocrit. Device values are continuously updated at varying intervals.

Figure 3. Cobe versus actual hematocrit.

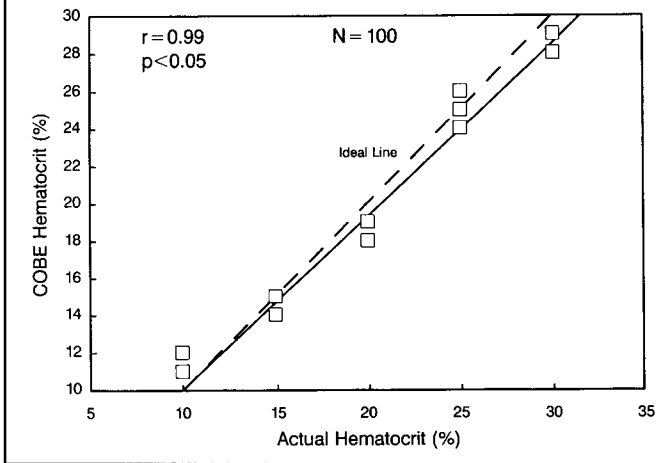

Figure 4. Gish versus actual hematocrit.

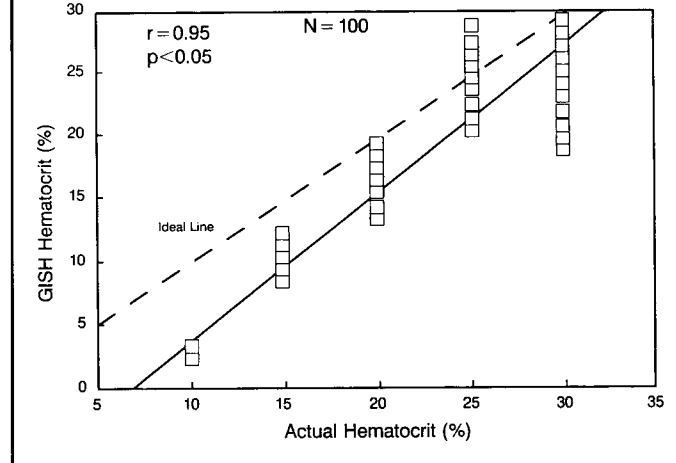

Figure 5. IBC versus actual hematocrit.

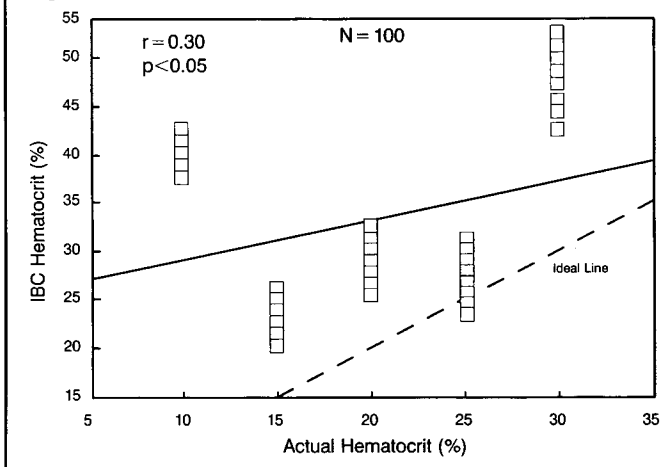
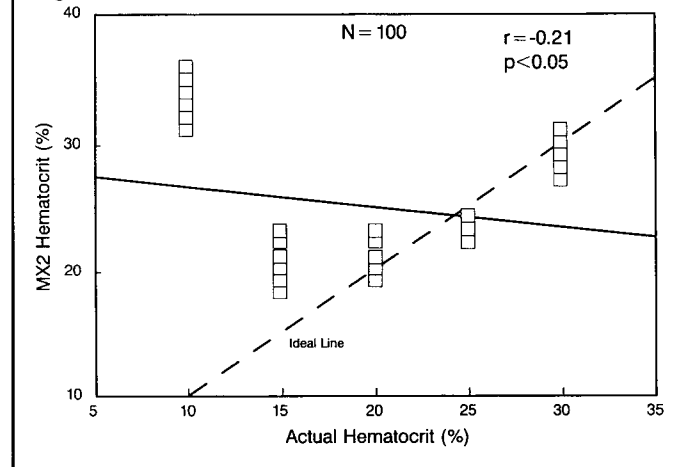

Figure 6. MX2 versus actual hematocrit.



The mean error, shown in Table 1, reflects device error. Positive values suggest device tendency to overestimate actual hematocrit, and negative values reflect device tendency to underestimate actual hematocrit. In general, error was most pronounced at hematocrits less than 15% and greater than 25%. It should be noted that the minimum operational limits for hematocrit, established by the manufacturers of most of these devices, is 15%. The study design was devised to examine the functional limits of these devices in clinically relevant situations, which in some situations could result in dilutional hematocrits less than 15%. All other protocol test parameters are within the suggested ranges for use. Statistical analysis of the data with the omission of the lowest hematocrit (10%) yielded reduced error for all devices (Table 1), but only the error of Cobe and the MX2 were within the manufacturers stated tolerances for error.

The correlation of time of evaluation with device error was also examined. All device error was found to be statistically correlated with time, with the exception of the Cobe device ($p < 0.05$). Study protocol dictated that each device be calibrated per manufacturers specification, and then not be altered thereafter.

Finally we needed to quantify the need for in vivo calibration, which is reflected by significant error versus time correlation, found in most devices. Evaluations were conducted utilizing each of these devices under identical operating conditions, to minimize the possibility of operator error that may have influenced statistical results.

Additional criteria in judging the clinical usefulness of these devices may be of a more subjective nature. Features of interest include serial port communication output (RS232) found in the MX2 and the CDI 100; data trending, incorporated into the design of the CDI 100 and Gish devices; and the ability to recalibrate a device once in operation, which is available with the CDI 100, Cobe, Gish, and IBC devices. An added consideration related to the Cobe monitor, is that it must be used in conjunction with a Cobe venous reservoir, utilizing built-in saturation/hematocrit fittings.

The usefulness of in-line monitoring is now being recognized for its ability to provide optimal patient care. In-line monitoring is a useful adjunct in alerting the perfusionist to sudden physiologic changes, in real time fashion, which imparts

a greater degree of safety in virtually any cardiopulmonary bypass procedure. The use of these devices does not circumvent, and is not intended to be a substitute for, appropriate physiologic monitoring, but reflects trends in patient status that may lead to more prudent decisions regarding patient treatment modalities. Based on our results, we believe that these devices can be operated cost effectively, by minimizing the need for excessive laboratory analysis. Our conclusions, based on experimental testing and analysis, suggest that: 1.) all device error was statistically correlated with time with the exception of the Cobe device; 2.) the error of each device tested was found to be correlated with actual spun hematocrits; and 3.) the Cobe saturation/hematocrit monitor had the lowest mean error overall, and the highest correlation with actual hematocrits, within manufacturers tolerances of $\pm 1\%$ hematocrit for values between 15 and 25%.

ACKNOWLEDGEMENT

The authors wish to thank 3M Health Care, Cobe Cardiovascular, Gish Cardiopulmonary, International Biophysics Corporation, and Medtronic Cardiopulmonary, for supplying the disposables and monitors for this study.

REFERENCES

1. Komer C. Physiologic changes of cardiopulmonary bypass. In: Casthely PA, Bregman D, eds. *Cardiopulmonary Bypass: Physiology, Related Complications, and Pharmacology*. Mount Kisco, NY: Futura Publishing Company, Inc.; 1991;37-84.
2. Galletti PM, Brecher GA. *Heart-Lung Bypass: Principles and Techniques of Extracorporeal Circulation*. New York: Grune and Stratton; 1962:5.
3. Bartlett RH, Delius RE. Physiology and pathophysiology of extracorporeal circulation. In: Kay PH, ed. *Techniques in Extracorporeal Circulation*. Oxford, UK: Butterworth and Heinemann; 1992;8-32.
4. Castillo JE, Bocchieri KA, Fryman P, Fermon C. Historical aspects of cardiopulmonary surgery. In: Casthely PA, Bregman D, eds. *Cardiopulmonary Bypass: Physiology, Related Complications, and Pharmacology*. Mount Kisco, NY: Futura Publishing Company, Inc.; 1991;1-22.
5. Mitchell BA, Casthely PA. Optimal flow during cardiopulmonary bypass. In: Casthely PA, Bregman D, eds. *Cardiopulmonary Bypass: Physiology, Related Complications, and Pharmacology*. Mount Kisco, NY: Futura Publishing Company Inc.; 1991;85-106.
6. Rajah MS, Penny AF. Haematological aspects of extracorporeal circulation. In: Kay PH, ed. *Techniques in Extracorporeal Circulation*. Oxford, UK: Butterworth and Heinemann; 1992;144-155.
7. Shah MV. Priming fluids for cardiopulmonary bypass. In: Kay PH, ed. *Techniques in Extracorporeal Circulation*. Oxford, UK: Butterworth and Heinemann; 1992;72-77.
8. Guyton AC. *Textbook of Medical Physiology*. Philadelphia: W.B. Saunders Company; 1991:356.
9. Ferries LH. Standards of care in perfusion: should not continuous in-line blood gas monitoring be one? *J Extra-Corpor Technol*. 1992;24:45-48.